

Aug. 26, 1930.

P. T. FARNSWORTH

1,773,980

TELEVISION SYSTEM

Filed Jan. 7, 1927

4 Sheets-Sheet 1

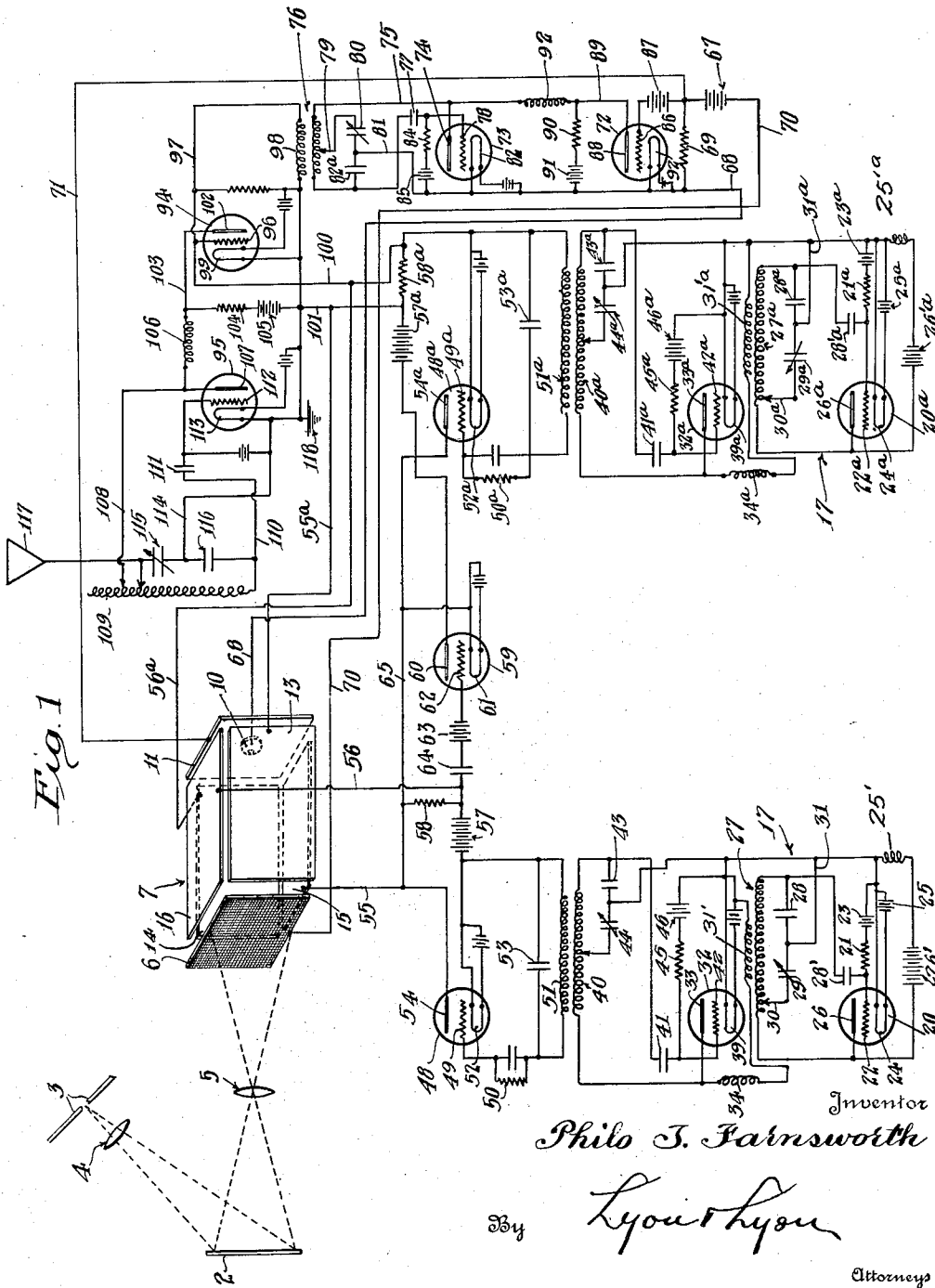

Aug. 26, 1930.

P. T. FARNSWORTH

1,773,980

TELEVISION SYSTEM

Filed Jan. 7, 1927

4 Sheets-Sheet 3

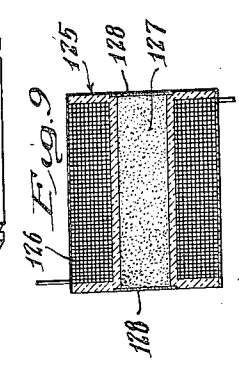
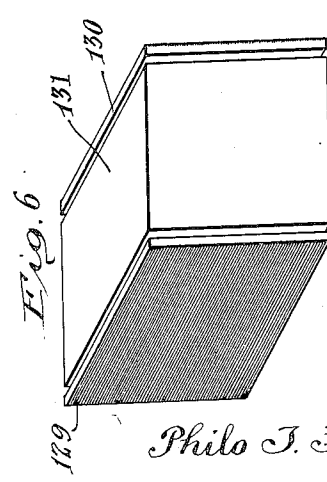
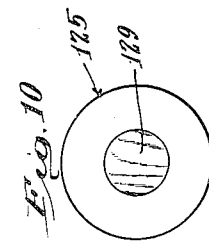
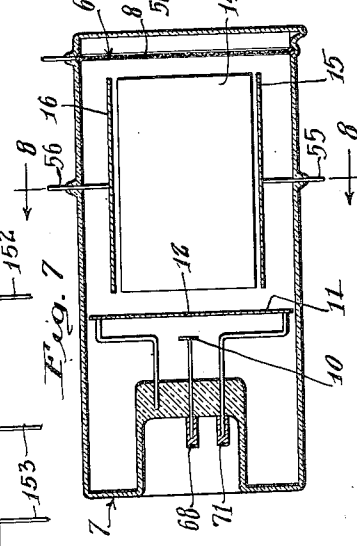
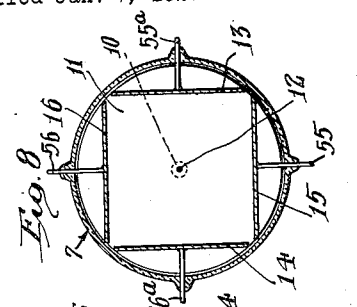
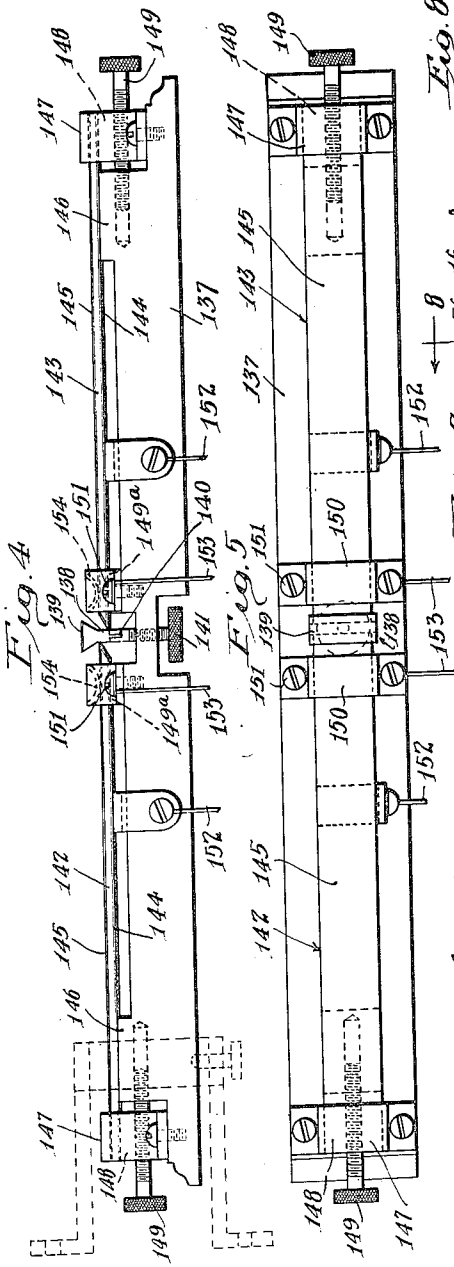

Inventor
Philo J. Farnsworth

By *Lyon Lyon*

Attorneys

Aug. 26, 1930.

P. T. FARNSWORTH

1,773,980

TELEVISION SYSTEM

Filed Jan. 7, 1927

4 Sheets-Sheet 4

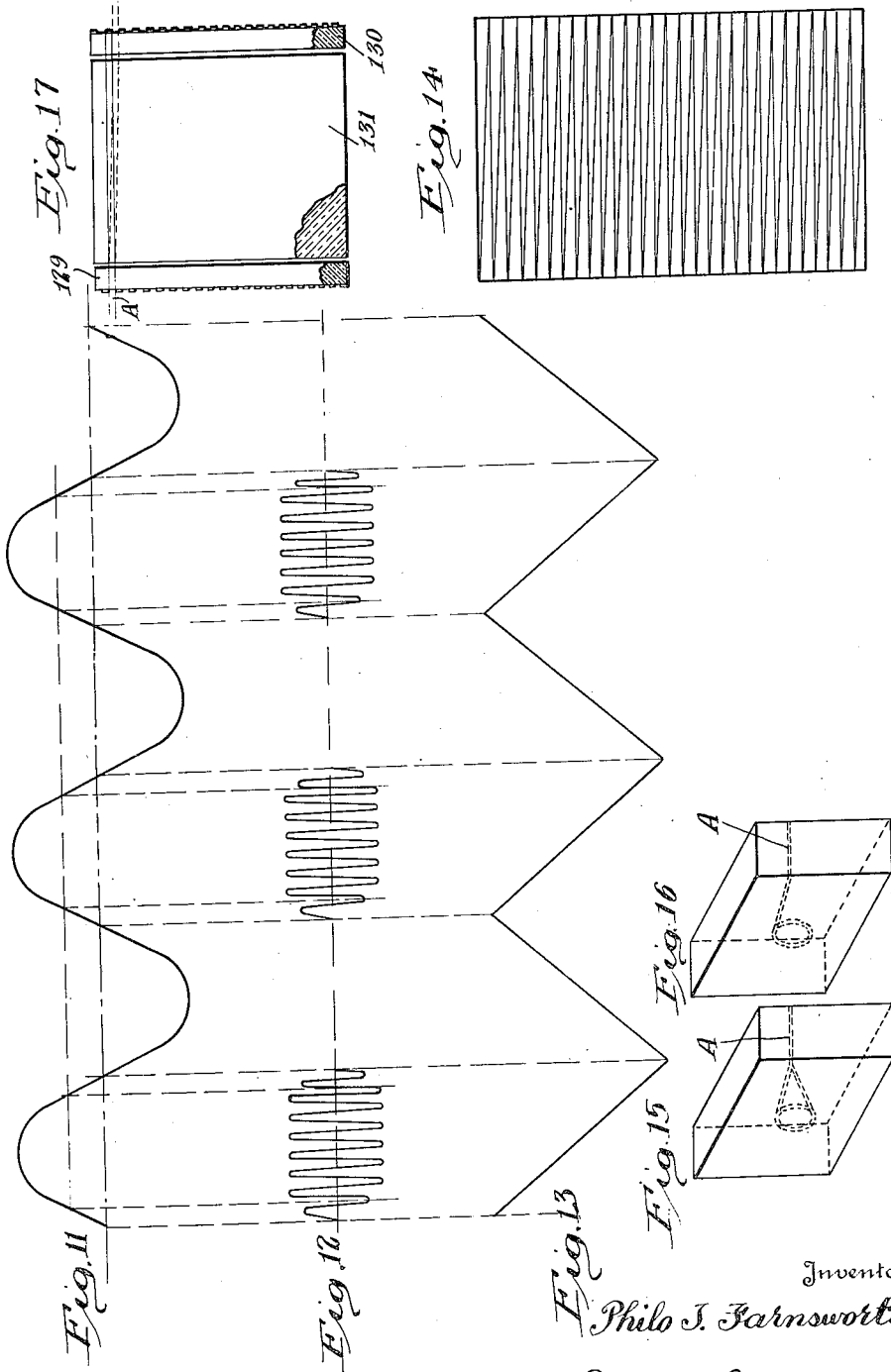

Inventor

Philo J. Farnsworth

By

Lyon Lyon

Attorneys

UNITED STATES PATENT OFFICE

PHILO T. FARNSWORTH, OF BERKELEY, CALIFORNIA, ASSIGNOR, BY MESNE ASSIGNMENTS, TO TELEVISION LABORATORIES, INC., OF SAN FRANCISCO, CALIFORNIA, A CORPORATION OF CALIFORNIA

TELEVISION SYSTEM

Application filed January 7, 1927. Serial No. 159,540.

This invention relates to a television apparatus and process, that is, it is directed to an apparatus and process for the instantaneous transmission of a scene or moving image of an object located at a distance in which the transmission is by electricity.

Heretofore attempts have been made to transmit an image of an object by electricity so that the image of the object will instantaneously appear at a distance. These prior attempts at television have generally embodied an apparatus and method in which each particular elementary area of the image of the object is successively converted into an electrical current, the intensity of which is proportional to the intensity of the light at that particular elementary area; all the elementary areas of the image being covered in that fraction of a second during which the eye will retain a picture, hereafter referred to as the optical period. This is followed by a transmission of such current and a conversion of such current to light corresponding in intensity to the intensities of the light of the individual areas of the original image; the reconversion process likewise being performed within the optical period so that, by a proper coordination of the developed light, an image of the object to be transmitted appears as instantly formed at the receiving end of the apparatus and method.

The time during which the human eye will retain a picture is of such short duration that the conversion of the light shades of the original image of the object to electricity and the reconversion of said electricity to light and the proper coordination of such light must be performed at a very tremendous speed. All prior attempts at television have attempted to employ some mechanically moving part for dissecting the image of the original object during the process of forming an electrical current which varies in intensity in accordance with the light shades of the respective elementary areas of the image. None of these prior attempts at television have proven successful. They have resulted at best in the production of a crude moving silhouette of the object to be transmitted. This has generally been due to the fact that

the mechanically moving parts of the prior apparatus have not been able to travel at the necessary speed requirements with the synchronism required in a television apparatus.

An object of the present invention is to provide a method and apparatus for television, which is adapted to transmit electrically a true moving image in full light shades of the object to be transmitted.

Another object of the present invention is to provide a method and apparatus for television in which the conversion and dissecting of the light shades of the object to be transmitted, to electricity and the reconversion of such electricity to form an image is accomplished in the following manner:

In the process and apparatus of the present invention, light from all portions of the object whose image is to be transmitted, is focused at one time upon a light sensitive plate of a photo-electrical cell to thereby develop an electronic discharge from said plate, in which each portion of the cross section of such electronic discharge will correspond in electrical intensity with the intensity of light imposed on that portion of the sensitive plate from which the electrical discharge originated. Such a discharge is herein termed an electrical image. An electrical shutter is then interposed between said sensitive plate and the anode of the photo-electrical cell, the shutter having a small aperture therein so that there can be received upon said anode at one instant, only the electrons which originate from one elementary area of the light sensitive plate. There is then imposed upon the electrical discharge a plurality of electrical potentials of different frequencies for causing the electrical discharge to bend in two directions, whereby the electrons from each elementary portion of the sensitive plate are successively directed through said shutter, this action taking place so as to completely cover the area of the sensitive plate within the optical period. The scene to be transmitted is thus analyzed or dissected to produce an electrical current or "light" current having variations in intensity in accordance with the light shades of the object to be transmitted and this is accomplished within the optical

period without the necessity of employing any mechanically moving parts.

The produced electrical current or "light" current may be transmitted to the receiving end of the apparatus by either wires or may be superimposed upon a wireless carrier wave. There is also transmitted at the same time and preferably superimposed upon the same carrier wave, the two electric potentials of different frequencies which are employed in analyzing the image so that such currents may be employed to synchronize the receiving apparatus and process.

At the receiving end of the apparatus and process, the "light" current is reconverted to light and the light coordinated to form an image of the object transmitted in accordance with the following apparatus and process.

Preferably a constant source of light is utilized which is directed, first, through a polarizing prism and hence through an apparatus or means by which the plane of polarization of the light may be rotated by the "light" current. In this manner an instantaneous response to the variations of such light current is obtained in the rotation of the plane of polarization of the light. The light is then directed through a suitable screen capable of shutting off the light in accordance with the rotation of its plane of polarization. In this manner, a beam of light is developed fluctuating in intensity to the variations of intensity of the "light" current transmitted without the necessity of employing any mechanically moving parts. This said beam of light is then projected by means of two cooperating oscillographs upon the screen where the image is to be transmitted, said oscillographs being operated by the synchronizing frequencies transmitted with the "light" current to correctly coordinate the light upon the screen to form a correct image.

The present invention, together with various objects and advantages thereof will best be understood from a description of a preferred form or example of a process and apparatus for television embodying the invention. For this purpose, I have hereinafter set forth one form of example of a method and apparatus for producing television in accordance with the present invention, and have illustrated said apparatus and method as it is adapted for television by wireless. It is to be understood, however, that the invention is capable of various and numerous modifications, changes, and substitutions, and is not necessarily limited to the transmission by wireless or radio.

The apparatus and method will best be understood from a description of the accompanying drawings, in which:

Figure 1 is a diagrammatic view of a complete television transmitter, including a circuit diagram therefor,

Figure 2 is a diagrammatic view of the television receiver,

Figure 3 is a circuit diagram of the electrical connections for the television receiver,

Figure 4 is an elevation of one of the oscillographs,

Figure 5 is a plan view of one of the oscillographs,

Figure 6 is a perspective view of the light diverting means,

Figure 7 is a sectional view of the photo-electric cell,

Figure 8 is a section on the line 8—8 of Figure 7,

Figure 9 is a section of the light rotator,

Figure 10 is an end view thereof,

Figure 11 is a representation of the form of electric current of the first oscillator employed in developing a potential for the photo-electric cell,

Figure 12 is a representation of the form of electric current produced in the second oscillator,

Figure 13 is a representation of the resulting straight lined potential,

Figure 14 is a view of the scanning path and also a view of the path of the light beam over the receiving screen,

Figure 15 is a perspective view of a bi-axial crystal showing the conical refraction of unpolarized light,

Figure 16 is a perspective view of a bi-axial crystal showing the refraction of polarized light, and,

Figure 17 is a diagrammatic illustration of the path of light through the gratings.

Referring to the drawings, 2 represents an object, an image of which is to be transmitted. Said object may be an actual scene or a photograph, a projection of a motion picture film, or any other object. The object is preferably illuminated, for example, by means of an arc light 3 focused thereon by a lens 4. 5 indicates a lens for focusing an image of the object 2, upon the light sensitive plate 6 of a photo electric cell 7.

The photo-electric cell is preferably constructed as follows:

The light sensitive plate 6 or cathode of the cell is preferably made flat and is formed of a fine mesh screen 8, and said screen 8 is covered or coated with a light sensitive material such as sodium, potassium, or rubidium. 10 is the anode of the photo-electric cell positioned at the other end of the cell. Between the sensitive plate 6 and anode 10 and closely adjacent to anode 10 is placed an electric shutter 11 formed by a metallic plate in which there is a small aperture 12. Between the shutter 11 and light sensitive plate 6, four plates 13, 14, 15, and 16 are placed at right angles to each other and outside the path of electrons from the plate 6 to the shutter 11. Each opposed pair of the plates are connected to a source of electrical

potential of a different frequency. The photo-electric cell should be highly evacuated, such for example as to 10^{-7} cm. mercury to permit a high potential across the cell without ionization.

The necessity for employing a high potential across the cell arises from the fact that the photo electrons emitted from the cathode 6 have a small emission velocity which depends upon the color of the light causing their emission. This emission velocity is always small, of the order of that which an electron would acquire by falling through a volt or two, but it may have nearly any direction. This haphazard motion tends to distort the electric image and is only prevented from doing so by making the potential between the cathode 6 and the anode 10 high enough to insure that the time taken for an electron to traverse the distance between cathode 6 and anode 10 is so small that the small velocity transverse to this path produces no appreciable distortion. Hence the vacuum in the photo-electric cell 7 should be the highest obtainable.

The electrical potentials are provided by an oscillator 17, capable of developing two different high frequency electrical currents. Said oscillator 17 not only is required to provide a source of oscillating energy but is required to provide a form of oscillating energy, the wave form of which is composed of substantially straight lines, as will be hereinafter pointed out. Such a wave form is essential to accomplish a uniform lighting of all portions of the image which is to be produced.

The oscillator comprises a tri-electrode valve 20 connected in a circuit acting as an oscillator to produce an oscillating energy of low frequency, such for example as 10 cycles per second. It is understood that any customary or preferred form of circuit for this purpose may be employed, the particular circuit described being provided with a grid leak 21 connected with the grid 22 of the tube 20, and hence through a negative bias battery 23 to the filament 24. The filament 24 is indicated as heated by a battery 25. The plate 26 of the tube is connected through a battery 26' and the choke coil 25' to the filament 24. The plate 26 also connects through an inductance 27 and capacity 28' with the grid. The inductance 27 is shunted by a fixed capacity 28 and a variable capacity 29 in series, one end of the series being connected to the end of the inductance 27 and the other end having a variable connection with said inductance. Between these capacities 28 and 29, a lead 31 is connected which connects with the filament 24 of the tube 20.

By this connection, the constants of the oscillating circuit may be any value of inductance and capacity to bring the oscillating

circuit in resonance with the frequency of the desired circuit. Said oscillator in turn provides a source of potential for a second oscillating circuit of similar design, the second oscillator operating at a higher frequency such, for example, as 500 kilo-cycles. The second oscillator comprises the tube 32, the plate 33 of which is charged with the oscillatory energy of the first oscillator. The first oscillator is coupled thru the secondary coil 31' to plate 33, the inductance 34 being included in series therewith. The inductance 34 may be any suitable radio frequency choke to prevent the high frequencies in the second oscillating circuit from being imposed on the first oscillating circuit. The plate 33 is connected through the primary 40 of a radio frequency transformer and hence through the capacity 41 with the grid 42. Capacities 43 and 44 are shunted around all or part of the primary 40 and a lead is connected from their midpoint to the filament 39 of the tube 32. The grid 42 of the tube is connected through a suitable leak 45 and negative bias battery 46 with filament 39. It is understood that the second oscillating circuit thus described is only one example of a circuit adapted for this purpose and the various constants of the circuit may be of any value suitable for bringing the circuit into resonance with the frequency of the oscillations (500 kilo-cycles) desired to be produced therein.

The voltage of the first oscillator is adjusted to be well above the value required for maximum plate current of the second oscillator. Hence, since the second oscillator will generate oscillations only when the plate voltage is positive, the current generated by the second oscillator will be similar to that shown in Figure 12. The harmonic oscillating current developed by the first oscillator is represented in Figure 11. This current, when imposed upon the second oscillator, develops a current such as illustrated in Figure 12, in which it will be seen that each positive cycle of the first harmonic current produces a series of harmonic oscillations in the second oscillator of substantially equal intensity, while during the negative period of the first harmonic current, substantially no oscillations are developed in the second oscillator.

The output from the second oscillator is then imposed upon an audion circuit having a tube 48 with its grid 49 connected by a line through the grid leak and grid condenser 50 to an inductance 51 inductively coupled to the inductance 40. Said secondary 51 is connected to the filament 52 of the audion 48. Shunted across the secondary 52 is a condenser 53 of value suitable to produce resonance with the oscillations developed in the second oscillator. The plate 54 and the audion 48 is connected by the lead 55 with the plate 15 of the photo-electric cell, and the opposed plate 16 of the photo-electric cell is connected by

a lead 56 through the battery 57 to the filament 52. The resistance 58 is shunted across the leads 55 and 56 to provide a potential for the plates 15 and 16.

5 The action of the audion circuit including the tube 48 is to produce an alternating current equal to the frequency developed in the first oscillator but the wave form of said frequency is of substantially straight lines such, for example, as indicated in Figure 13. In 10 producing this wave form, the audion tube 48 operates due to the bias of the grid leak and condenser 50 to accumulate a charge during the passage of each wave train indicated in 15 Figure 12, and such accumulated charge leaks off during the interval between successive trains, so that the output of the audion 40 into the plate circuit, indicated by the leads 55 and 56 (passing to the plates 15 and 16 of the 20 photo-electric cells) assumes the straight line form of Figure 13.

There is also a duplicate form of audion circuit for supplying a similar wave form of electrical oscillations for the plates 13 and 25 14 of the photo-electric cell, said oscillations being, however, at a higher frequency such, for example, as 5000 cycles per second. Inasmuch as this circuit is identical except in value of constants to the circuit just described, 30 the parts corresponding to those numbered 20 to 54 are numbered 20^a to 54^a. It is understood that the oscillating tube 20^a develops a harmonic oscillating current of 5000 cycles which will be imposed upon the oscil- 35 lator including the tube 32^a, operating at 500 kilo-cycles producing a straight line alternating current in tube 48^a of a frequency of 5000 cycles per second. The output from tube 48^a to the plates 13 and 14 is from filament 40 52^a, through resistance 58^a, battery 57^a, and hence through a modulating tube 59 through the plate 60 thereof, and to the filament 61 thereof, and hence to the plate 54^a of the tube 48^a. The potential drop 45 across resistance 58^a is utilized to provide the potential for plates 13 and 14 through leads 55^a and 56^a. The modulated tube 59 has its grid 62 connected through the negative bias battery 63 and condenser 64 with lead 56 while the filament 61 is connected to lead 65 with the lead 55. In this way, the tube 61 50 acts to modulate the low frequency from the first oscillator circuit upon the higher frequency of the second oscillating circuit.

The potential for the photo-electric cell is provided by a battery 67. The negative terminal of the battery 67 is connected by a line 70 with the light sensitive plate 6 of the photo-electric cell and the positive terminal of the battery 67 is connected through a resistance 69 to a lead 68 connecting with the anode 10 of the photo-electric cell. The battery 67 has preferably a high potential, such as the order of 1000 volts and the resistance 69 is of high resistance such, for example, as

one megohm, in order that the drop across such resistance induced by the fluctuations of light in the photo-electric cell may be amplified before being transmitted. The shutter 11 of the photo-electric cell is connected by 70 line 71 to the positive terminal of the battery 67 between the resistance 69 and the battery 67 so that it operates at the same potential as the anode 10 of the cell but its current supply does not pass through the resistance 69. 75

The effect of the potential applied to the plates 13 and 14 is to cause the electric discharge from the light sensitive plate 6 to be bent back and forth between the plates 13 80 and 14 at a frequency corresponding to the frequency of the electric potential imposed on the plates 13 and 14 (for example, 10 cycles per second). The effect of the potential applied to the plates 15 and 16 is to cause 85 the electric discharge from the light sensitive plate to be bent back and forth between the plates 15 and 16 at a frequency corresponding to the frequency of the electric potential imposed on the plates 13 and 14, (for example, 90 5000 cycles per second). The resulting effect is the same as if the opening 12 of the shutter 11 was mechanically moved over the light sensitive plate in accordance with the line shown in Figure 14, in which the sub- 95 stantially parallel lines indicate the movement caused by the potential on the plates 15 and 16. The oscillations of the electric discharge in the direction at right angles to the lines of Figure 14 is caused by the potential 100 on plates 13 and 14, causing the image on the plate 6 to be traversed once every 1/20th of a second with a 10 cycle per second potential. During this period of time, the 5000 105 cycle per second frequency imposed on plates 15 and 16 will have caused five hundred passages across the image as contrasted with the other television attempts which have succeeded in securing only about thirty-five lines 110 across the image during the optical period. Moreover, it is understood that the frequencies imposed on the plates 13 to 16 inclusive may be increased without limit (up to at least ten thousand kilo-cycles per second), giving 115 any desired number of passages over the image within the optical period, or to make the optical period as short as desired.

There will now be described the apparatus utilized for amplifying the light current and for transmitting such current on a wireless 120 carrier wave, together with the two analyzing oscillator currents or potentials employed on the plates 13 to 16 inclusive, of the photo-electric cell. The transmitting means comprises the tube 72, said tube operating both 125 as an amplifier of the light current and as a modulator of a further tube 73, it being illustrated as in a Heising modulating circuit. The tube 73 produces a first carrier wave of suitable frequency such, for example, as of 130

about 500 kilo-cycles. For this purpose, the tube is illustrated as having its plate 74 connected by lead 75 with an inductance 76, the opposite end of which is connected through the condenser 77 to the grid 78 of the tube.

The inductance 76 is tapped in the center by a variable tap 79 which connects to a variable condenser 80 and hence by a line 81 to the filament 82. The condenser 80 and the coil 76 may have any values provided that the condenser 80 and the inductance 76 are adapted to bring the circuit in resonance with the carrier wave to be produced. The line 81 is also connected with the line 77 by a condenser 82^a. The grid 78 is also connected with the filament 82 through a grid leak 84 and negative battery 85. The potential for the tube 73 is provided by the battery 91, through the resistance or choke 90. The tube 72 acts as a variable resistance across 90 and 91, increasing or decreasing the potential drop and thereby modulating the potential on plate 74 of the tube 73. The tube 72 has its grid 86 connected by a negative bias battery 87 with the resistance 69, across which there is imposed the "light" potential whereby said "light" potential is amplified in the tube 73. The plate 88 of the amplifying and modulating tube 72 is connected by a line 89 through a choke or resistance 90 and a battery 91, the negative side of which is connected with the filament 92 of the tube 72 and also with the filament 82 of the oscillating tube 73.

The choke 90 operates to fluctuate the potential supply to the plate of the oscillating tube in accordance with the amplified light current. In the lead between the choke 90 and plate 74 is provided a choke 92 which prevents the carrier wave produced in the oscillator 73 from being imposed upon the amplifying and modulating tube 72 by the circuit thus described. The carrier wave produced in the oscillator 73 is modulated by the amplified light current. This potential is then imposed upon a double modulating tube 94 which operates to modulate an oscillator 95 producing a second carrier wave of higher frequency, such for example as 1500 kilo-cycles, or the wave length to be transmitted.

Said double modulator tube 94 not only modulates the second carrier wave with the modulated first carrier wave from oscillator 73, but also modulates said carrier wave with the analyzing potentials from the modulator tube 59. The double modulating tube 94 has its grid 96 connected by lead 97 with a coil 98, the coil 98 being connected to the filament 99 of the double modulating tube. By this means, the output from the oscillator 73 is imposed upon the double modulating grid. The analyzing potentials are imposed upon the grid 96 by a lead 100 which connects across the resistance 58^a and hence by a lead 101 to

the filament 99. The tube 94 is part of a Heising modulator that has its plate 102 connected by a lead 103 through a radio frequency choke or resistance 104 to the positive terminal of battery 105, the negative terminal of which is connected with the filament 99. The lead 103 also connects with the radio frequency choke 106 to the plate 107 of the oscillator tube 95. The choke 106 prevents upon the double modulating tube 94 while the choke or resistance 104 fluctuates the potential supply to the plate 107 of the oscillator 95 in accordance with the output of the double modulating tube 94. The plate 107 connects with the lead 108 to an inductance 109 producing the second carrier wave, said inductance being connected with the lead 110 through condenser 111 with the grid 112 of the oscillator tube 95. The filament 113 of the tube is connected by lead 114 through a variable condenser 115 to the inductance 109. There is also a condenser 116 between the lead 114 and the grid leak 110. The inductance is also connected with an antenna 117 or other means for radiating the output from the transmitter. The filament 113 is grounded as indicated at 118.

The receiver of the television apparatus and process is constructed and operates as follows: Preferably there is employed a source of light of constant intensity, such as an arc light 120 and to obtain a pencil of light therefrom, there is placed a shutter 121 with a small aperture 122 in front of the arc light. The light from said shutter is then passed through a polarizer 123. The polarizer is indicated as preferably in the form of a Nicol prism. The polarized light from the Nicol prism 123 is then passed through a lens 124 which parallels the polarized light and the paralleled light is then passed through a device 125 for rotating the plane of the polarized light. The device 125 may be any device suitable for rotating the plane of the polarized light in accordance with the fluctuations of the light current received at the receiver. The method of receiving and separating this light current from the transmitted wave will be hereinafter pointed out. The preferred form of such device is illustrated as comprising a means for producing a magnetic field fluctuating in accordance with the light current, such as the coil 126, surrounding an electrically optically active medium 127, such for example as a thin film of iron, cobalt, or nickel, or carbon disulfide, glass, or any other material in which a beam of polarized light rotates considerably when subjected to a magnetic field. I prefer to employ carbon disulfide and said carbon disulfide is held in the core of the coil 126 by glass plates 128.

The light from the light rotator 125 is then passed through a device adapted for restrict-

ing the passage of light in accordance with its degree of rotation. I preferably employ a combination of a pair of gratings 129 and 130 and a bi-axial crystal 131. The gratings 129 and 130 may be any usual form of light gratings, for example, ruled upon a silvered transparent surface, and are placed at opposite ends or sides of the bi-axial crystal with their gratings opposed. The bi-axial crystal employed between the gratings is adapted to produce a conical refraction of the light. As an example of a suitable crystal of this kind, I have employed a crystal of arragonite one centimeter thick between the gratings ruled with 100 lines per millimeter. With this combination, the rotation between complete extinction and complete restoration is of the order of two degrees. Thus with this analyzer, very small currents may be employed upon the rotator, permitting the use of a coil of very high natural period.

The operation of this analyzer will best be understood from Figures 15, 16 and 17, in which Figures 15, 16 and 17 there is disclosed how a rotation of a few degrees will change complete extinction to complete restoration. A indicates a beam of light passing through the first grating 129 and hence through the bi-axial crystal 131 to the second grating 130, the lines of which are opposed to the lines of the grating 129. If the beam of light passes directly through the bi-axial crystal, it is completely extinguished by the lines of the grating 130 but if the plane of polarization of the beam A is rotated slightly, the ray A will take the direction of the dotted lines through the crystal and pass between the lines of the grating 130, a slight difference in refraction of the light in the bi-axial crystal 131 being sufficient for this purpose.

In explanation of the action of the bi-axial crystal 131, it is understood that the light is directed on said crystal along one of its optic axes. When this is done, the light is refracted to an extent depending on the position of the plane of polarization. When unpolarized light from an aperture is directed on such a crystal along one of its axes, said light will appear as a circle from the other side of the crystal, but when a beam of polarized light is directed along one of the axes of the crystal, it appears as a point of light lying in the circle produced by the unpolarized light, but its position is dependent on the position of the plane of polarization of the beam of light. A 90 degree rotation of the plane of polarization of the beam of light will rotate the light from the crystal from one side of the circle 8 to the opposite side. The two extreme positions of a polarized beam of light are indicated in Figure 15, by the two branches of the beam of light A. During the passage of the light through the bi-axial crystal, the wave front of the beam of light remains parallel and the wave front of the beam

passes through perpendicularly to the optic axis of the crystal.

By means of the polarizer 123, light rotator 125, and analyzer comprising the gratings 129 and 130 and the bi-axial crystal 131, the constant supply of light through arc light 120 is caused to produce a light of varying intensity, varying in accordance with the intensity of the light current supplied to the coil 126. Thereby, without the employment of any mechanical moving apparatus, the light current is reconverted into light.

Such light is then passed through a lens 132 by which it is focused upon a pair of cooperating oscillographs 133 and 134. Said cooperating oscillographs 133 and 134 are positioned at right angles one to the other and so that the light from one strikes the other oscillograph. Said oscillographs are operated at different frequencies with the result that the light is by said oscillographs projected in horizontal vibrations, which are successively lowered or raised vertically so that the light can pass through a lens 135 upon a screen 136 and covers successively an entire rectangular area of said screen. The oscillographs 133 and 134 are operated by electrical currents of the frequencies of the two analyzer currents applied to the plates 13 to 16 of the photo-electric cell so that the passage of the beam of light over the screen 136 is in synchronism with the bending of the electrical discharge from the sensitive plate 6 of the photo-electric cell and thereby each portion of light is properly coordinated to produce a correct image of the object being transmitted.

The details of the construction of the oscillographs 133 and 134 are shown in Figures 4 and 5, only one of the oscillographs being illustrated since they are of similar construction. The oscillographs comprise a base or body 137 of any suitable material. In the center thereof, is mounted a quartz strip 138 having a silvered mirror surface 139 at its top. Said quartz strip vibrator 138 is held in a holder 140 which is vertically adjustable by a set-screw 141. The quartz strip vibrator is engaged at opposite sides and at points spaced apart slightly vertically by a pair of quartz strips 142 and 143 laid horizontally and plated at the tops and bottoms by a metallic plating, such as copper, as indicated at 144 and 145. The outer ends of such quartz strips 142 and 143 engage guides 146 on the body, and hence engage clamps 147 by which they are held to carriers 148. The clamps 147 are connected by adjusting screws 149 to the body 137 by means of which the quartz strips 142 and 143 may have their pressure against the quartz strip vibrator 138 adjusted. At the inner ends of the quartz strips 142 and 143 are placed rests 149^a over which are placed a resilient material, such as rubber, and thereabove is placed a further quantity of rubber.

Clamps 150 are placed over the top of the inner ends of the quartz strips and connected with adjusting screws 151 by means of which the vertical positions of the ends of the quartz strips may be adjusted. It is understood that in the showing of Figures 4 and 5, the quartz strips are greatly exaggerated in thickness inasmuch as in practice such strips are very thin, approximating the thickness of a sheet of paper, and are cut with their thickness in the direction of the electric axis, their length in the direction of the axis of extension and their width along the optic axis of the crystal. The bottom sides of the strips 142 and 143 are connected by conductors 152 while the top plating on the strips is connected by conductors 153 connected with springs 154 at the top of the clamps 150.

Referring to Figure 3, the electrical apparatus for receiving the transmitted wave in the transmitter and correctly applying the light current and analyzing currents to the light rotator 125 and oscillographs 133 and 134 is as follows: 155 indicates a receiving antenna or other means for collecting wireless waves which antenna is connected through an inductance 156 to a ground indicated at 157. Inductance 156 forms a primary of a transformer in which the secondary 158 is in the grid circuit of a detector 159. 160 indicates a tuning condenser for bringing the receiver in resonance with the carrier wave of the transmitter. The plate 161 is indicated as connected to a plurality of filters, the first of which comprises the inductance 162, the voltage across which is applied to the grid of a second detector 164. The first filter comprising the inductance 162 should be in resonance with the first carrier wave developed in the transmitter or tube 159 thereof. There is thus imposed upon the grid of a detector tube 164 a current comprising the light current modulated upon the first carrier wave formed in the transmitter. In the detector 164, such carrier wave is detected to produce a current output from the plate 165, which is equivalent to the light current developed in the transmitter. In the second detector circuit 164, 166 indicates a condenser for passing the high frequency and blocking the low frequency currents, and 167 indicates a battery for supplying the plate potential. The plate 165 is indicated as connected with the coil 126 of the light rotator.

The complete circuit of the detector tube 159 also includes a condenser 168 of a capacity suitable for by-passing the high frequency of the first carrier wave which is detected by the tube 164 and of a capacity to block the frequency of the analyzing currents. Such analyzing currents are therefrom passed through a choke 169 and line 170 to one of the oscillographs 133, connecting for example with the top platings of both of the quartz strips thereof, the bottom plating of the

quartz strips of said oscillographs 133 being connected by a line 171 with a resistance 200 shunted across line 170, and line 201 which line connects with the opposite side of the condenser 168. By this connection, the oscillograph 133 is operated by the higher analyzing frequency, i. e., the 500 cycles per second frequency. Said frequency also passes through the grid leak 172 to a grid 174 of a detector tube 173 wherein said frequency is detected to deliver from its plate 175 a potential of the frequency of the first analyzing current, or 10 cycles per second. The plate 175 is indicated as connected by the line 176 to the resistance 202 which is connected by a tap 203 to the top plating of the oscillograph 134 and the bottom plating of the oscillograph 134 is indicated as connected by line 177 through the battery 178 to the filament 179 of the detector 173. The filament 179 is also connected by the lead 180 with the condenser 168. The resistance 200 and 202 provide a means for controlling the potential of the currents applied to the oscillographs.

It will be readily apparent from the description of the apparatus and operation thereof, how the detected light current imposed upon the coil 126 modulates the light in accordance with the intensity of light at the particular point from which said light current originated from the light sensitive plate 6. It will also be seen that said light is projected upon the screen 136 by the oscillations of the oscillographs 133 and 134 to form a correct image of the object transmitted, the light being caused to travel back and forth across the screen similar to the action of the shutter 11 of the transmitter, making the example given 500 reciprocations across the screen in covering the complete area thereof, and said reciprocations are made within a period of 1/20th of a second. It is understood, however, that the process and apparatus of the present invention is not necessarily limited to the use of the particular frequencies given for the purpose of facilitating the description of a preferred process and apparatus.

The process and apparatus of the present invention permit the selection of such small elementary areas of the image to be transmitted that the produced image on the screen 136 follows all of the light shades of the object, producing a correct image thereof. This is accomplished without the employment of mechanically moving parts, excepting the vibrating strips of the oscillographs. The apparatus is thus free from mechanical problems.

While the process and apparatus for producing television herein described is well adapted for carrying out the objects of the present invention, it is understood that various modifications and changes may be made without departing from the invention, and

the invention includes all such modifications and changes as come within the scope of the following appended claims.

I claim:

- 5 1. The method of television which includes forming an electrical image, and traversing each elementary area of the electrical image by an electric shutter at a velocity sufficient to cover the entire image within the optical
10 period.
2. The process of television which comprises forming an electrical image, moving said electrical image in more than one direction by an analyzing potential, and varying
15 the intensity of an electric current in accordance with the position of the electrical image.
3. The method of television which comprises focusing an image of an object upon the sensitive plate of a photo-electric cell, imposing a shutter in the path of the electrical
20 discharge from said plate, and forming transverse to the electrical discharge two electrical potentials of different frequencies.
4. An apparatus for picture dissecting
25 comprising a cell having a plate of photo sensitive material, an anode, a plurality of plates positioned between the photo sensitive plate and anode, and means for imposing upon said plates a plurality of electrical potentials of
30 different frequencies.
5. An apparatus for dissecting an image comprising a cell having a photo sensitive plate, an anode, a shutter between the anode and plate, and electrical means for bending
35 the electrical discharge from said plate.
6. The method of television which comprises forming an electrical discharge which corresponds in cross section in electrical intensity to the light intensity of an image to
40 be transmitted, transmitting successive portions of said electric discharge, and modulating light thereby.
7. A method of television which comprises analyzing an image into elementary areas,
45 producing a train of energy varying according to the intensity of light of said areas, all of the elementary areas being covered within the optical period, causing said train of energy to modulate a source of light of constant intensity according to the light of said
50 areas, and correlating successive portions of said light to reform said image, said latter operation being completed within the optical period.
8. A method of television which comprises producing an electrical oscillation having a substantially straight line wave form, utilizing
55 said electrical potential to analyze an image into elementary areas, producing a train of energy varying according to the intensity of light of said areas, and converting said train of energy into light varying according to the light of said areas.
9. A method of television which comprises
65 producing an electrical oscillation having a substantially straight line wave form, utilizing said electrical potential to analyze an image into elementary areas, producing a train of energy varying according to the intensity of light of said areas, and utilizing said electric potential of substantially straight line wave form to correlate successive portions of said light.
10. A method of television which comprises producing two electrical potentials of different frequencies, each of said electrical potentials having substantially straight line wave forms, causing said electrical potentials to analyze an image into elementary
70 areas, producing a train of energy varying according to the intensity of light of said areas, and converting said train of energy into light varying according to the light of said areas.
11. A method of television which comprises producing two electrical potentials of different frequencies, each of said electrical potentials having substantially straight line
75 wave forms, causing said electrical potentials to analyze an image into elementary areas, producing a train of energy varying according to the intensity of light of said areas, converting said train of energy into light varying according to the light of said areas, and causing said electrical potentials of different frequencies to correlate successive portions of
80 said light to reform said image.
12. In a system of television, analyzing an
85 image into elementary areas by causing a scanning device to scan all elements of said image successively at a substantially uniform velocity, over a continuous path reciprocating transversely of the image and the reciprocations having a slow motion transverse thereto.
13. A method of television which comprises forming an electrical image, moving the image in two directions over an electrical shutter having a small aperture, thus forming an
90 electrical current which is a function of the intensity of the portion of the electrical image at said aperture.
14. A method of television which comprises forming an electrical image, impressing upon
95 said image two electrical potentials of different frequencies, thereby causing said image to move in two directions respecting an electrical shutter and forming an electric current from the portion of the electrical image registered with the electrical shutter.
15. An apparatus for television which comprises means for forming an electrical image, and means for scanning each elementary area
100 of the electrical image, and means for producing a train of electrical energy in accordance with the intensity of the elementary area of the electrical image being scanned.
16. An apparatus for television which comprises means for forming an electric image, 105

means for moving said electric image in more than one direction by an analyzing potential, and means for varying the intensity of an electrical current in accordance with the position of the electrical image.

5 17. An apparatus for television which comprises means for focusing an image of an object upon the sensitive plate of a photo-electric cell, said photo-electric cell having an anode
10 therein to receive an electrical discharge from said plate, said cell having a shutter in the path of the electrical discharge from the sensitive plate, said cell having plates positioned transverse to the electrical discharge, and
15 means for imposing upon said plates electrical potentials of different frequencies.

18. An apparatus of the class described, including an oscillator, an oscillator of higher frequency operated by the oscillations from
20 the first oscillator, thereby producing successive trains of oscillations during the positive cycle of oscillations of the first oscillator, a device for accumulating and discharging said
25 oscillations thereby producing oscillations having substantially straight lined wave form, similar means producing an alternating potential of straight lined wave form and higher frequency, means for utilizing said potentials to scan an image in two directions,
30 means for modulating the lower frequency upon the higher frequency, means for producing a train of energy varying in intensity in accordance with the area scanned, means for modulating a carrier wave with said train of
35 energy and said scanning potentials, means for receiving and detecting said train of energy and said analyzing potentials, means for modulating the light in accordance with said analyzing potentials, and means for correlating
40 said light to form an image actuated by said potentials having straight line wave forms.

Signed at San Francisco, California, this
21st day of December, 1926.

45 **PHILO T. FARNSWORTH.**

50

55

60

65